

FEATURES

Main features:

- elastic fixing of rails with or without pad;
- system made up of two interacting elements that allow an easy lateral adjustment of the rail;
- easy maintenance;
- the elastomer nose increases the tolerances of the rail support structure, reduces the stress of the connections and allows a better fixing of the rail;
- the fastening system has been used for years throughout the world in the most demanding conditions with great success.

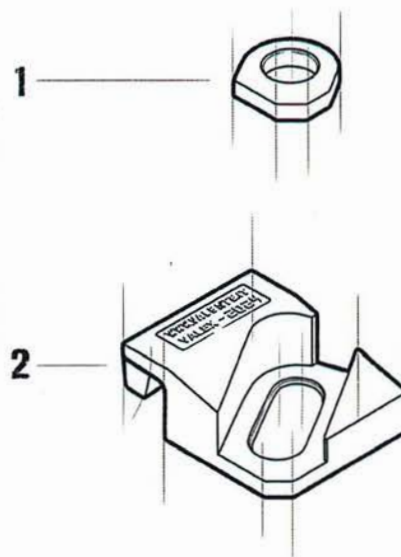

COMPONENTS

- 1 Special Washer
- 2 Clip with vulcanized rubber nose

APPLICATIONS

The fastening system Valex 2024 for direct fixing has been studied specifically for crane rails but it can be used with good results also with train and light rails.

It is a very rugged, reliable fastening system of contained dimensions.

It can be used with any type of crane independently of the driving system.



<i>Dimensions [mm]</i>	<i>E</i>	<i>F</i>	<i>G</i>	<i>H</i>	<i>L</i>	<i>L1</i>	<i>L2</i>	<i>M</i>	<i>N</i>	<i>O</i>	<i>P</i>	<i>Weight [g]</i>
VALEX 2024-42-9	-	-	-	23	-	-	-	-	-	-	-	975
VALEX 2024-42-13	-	-	-	19	-	-	-	-	-	-	-	965
VALEX 2024-42-18	-	-	-	14	-	-	-	-	-	-	-	955
VALEX 2024-42-23	-	-	-	9	-	-	-	-	-	-	-	945

RAIL TYPE	A [mm]	B [mm]	C [mm]	Weight [kg/m]	WITHOUT PAD	WITH PAD
A 45	45	55	125	22,1	-	-
A 55	55	65	150	31,8	-	-
A 65	65	75	175	43,1	-	-
A 75	75	85	200	56,2	-	-
A 100	100	95	200	74,3	VALEX 2024-42-9	VALEX 2024-42-13
A 120	120	105	220	100	VALEX 2024-42-9	VALEX 2024-42-18
A 150	150	150	220	150,3	VALEX 2024-42-13	VALEX 2024-42-18
CR 104	63,5	127	127	51,59	VALEX 2024-42-9	VALEX 2024-42-18
CR 105	65,1	131,8	131,8	52,09	VALEX 2024-42-9	VALEX 2024-42-13
CR 135	76,2	146	131,8	66,97	VALEX 2024-42-9	VALEX 2024-42-18
CR 171	101,6	152,4	152,4	84,83	VALEX 2024-42-13	VALEX 2024-42-18
MRS 87 A	101,6	152,4	152,4	86,8	VALEX 2024-42-13	VALEX 2024-42-18
CR 175	102,4	152,4	152,4	86,8	VALEX 2024-42-9	VALEX 2024-42-18
MRS 125	120	180	180	125	VALEX 2024-42-18	-
S 7	25	65	50	6,75	-	-
S 10	32	70	58	10	-	-
S 14	38	80	70	14	-	-
S 18	43	93	82	18,3	-	-
S 20	44	100	82	19,8	-	-
S 24	53	115	90	24,43	-	-
25 kg/m	50	115	90	25	-	-
S 26 (AFNOR 26)	50	110	100	26,27	-	-
27 E1 (27 UNI)	50	120	95	27,06	-	-
AFNOR 30	56	125,5	106	29,98	-	-
30 E1 (S 30)	60,3	108	108	30,13	-	-
33 E1 (S 33)	58	134	105	33,47	-	-
36 E1 (36 UNI)	60	130	100	36,26	-	-
40 E1 (S 41-R14)	67	138	125	40,95	-	-
46 E4 (46 UNI)	65	145	135	46,9	VALEX 2024-42-9	VALEX 2024-42-13
49 E1 (S 49)	67	149	125	49,39	VALEX 2024-42-9	VALEX 2024-42-13
50 E5 (50 UNI)	67	148	135	49,9	VALEX 2024-42-9	VALEX 2024-42-13
54 E1 (UIC 54)	70	159	140	54,77	VALEX 2024-42-9	VALEX 2024-42-13
60 E1 (UIC 60)	72	172	150	60,21	VALEX 2024-42-9	VALEX 2024-42-13

Clip can be used with more type of rails than those listed.
 Complete range of the usable rails available on request.
 Products and specifications could be changed without previous notice.

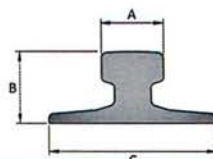

GENERAL INSTRUCTIONS

The selection of the fastening system, either for crane rails or train or light (Decauville) rails is a rather important decision both when placing a track or a single rail. The wrong selection could have expensive consequences and create serious problems such as:

- slow down or shut down of the production process,
- excessive and, or irregular wear of the rails,
- damage of the mechanical components,
- damage of the supporting base,
- damage of the fastening systems.

Valex fastening systems have been developed through the experience of more than 90 years of activity.

The Vallex fastening systems offer a practically unlimited selection of alternatives which allows for the most effective and efficient performance in nearly every possible situation.

ASSEMBLING INSTRUCTION

- Line up the rails;
- Place the clips in contact with the rails;
- Place the washer and insert the screw;
- Control the line up of the rails and the correct contact between the rails and the clips;
- Complete the tightening.

TECHNICAL SPECIFICATIONS

- Lateral adjustment 15 [mm]
- Side load 160 [KN]
- Torque tightening 550 [Nm]
- Bolt M24 gr 8.8
- Steel Quality S355JR

FIXING DETAILS

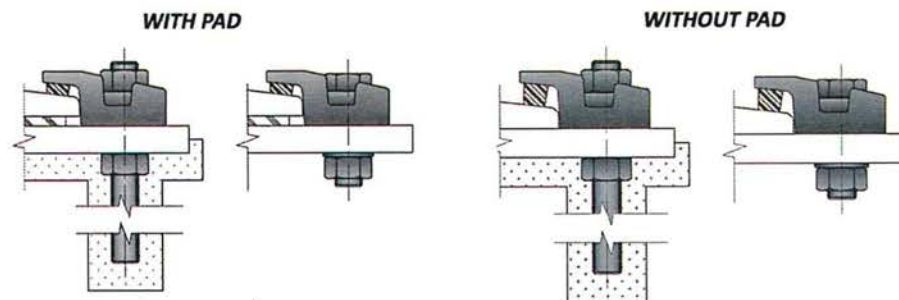

BOLT NOT INCLUDED